

Vortex flow sensors // VVX

US version available

Note: The US versions are separate products.
The units are not converted, but pre-configured at the factory for the respective variants.



VVX32 brass



VVX40 stainless steel



100 %

- Final water flow test
- Adjustment of output signal and calibration at 3 test points
→ Traceable measurement performance
- Recording of the test data
→ Test protocols available for customers
- Traceability via serial number

Combination sensor

- Combination of flow and temperature measurement
- Flow measurement with no moving parts
- Fast responding temperature measurement

µController

- Customisation through approx. 60 software parameters
- Software filter (optional)
→ exact flow measurement even with vibrations

On the test bench: 100% Final water flow test



encapsulated piezoceramic sensor element



Reliable

- Piezoceramic sensor element completely encapsulated
→ no direct medium contact
→ dirt-resistant and fail-safe
- Robust metal body
- CE Marking
- OEM product developed and produced in Germany

Test reports for customers

- SIKA test labs - many qualification tests
→ Temperature shock
→ Contamination
→ and many other tests
- Sample devices can be supplied with works test certificate

Reliable partnership with SIKA



- More than 45 years of experience with flow sensors in heaters
- Leading heat pump manufacturers trust in SIKA Vortex flow sensors

General information on the principle of operation

Alternate vortices rotating in opposite directions are generated behind a bluff body immersed in a flow. The vortices detach from the edges of the bluff body and form a Kármán vortex street in the fluid stream. The distance between the single vortices is constant. The frequency of the vortices flowing past a sensor depends on the flow rate and is proportional to the flow. The sensor detects these vortices which are then converted to an electrical frequency signal.

- Minimal flow obstruction → low pressure drop
- Independent of the conductivity of the medium
- High long-term stability / no zero drift

Technical data

Technical Data	VVX32	VVX40
Nominal diameter	DN 32	DN 40
Nominal pipe size	1½"	2"
Process connection	G 1½-ISO 228 male, incl. O-rings	G 2-ISO 228 male, incl. O-rings
Process connection	1½" NPT	2" NPT
Inner diameter [mm]	Ø 32	Ø 40
Inner diameter [inch]	1.3	1.6
Medium	Water and aqueous solutions	
Pressure rating	PN 16	
Pressure rating	Max. 232 psi	
Degree of protection EN 60529 with attached cable socket	IP65 and IP67	
Flow measuring		
Flow range [l/min]	12...250	22...400
Flow range [US gpm]	3.2...66	5.8...106
Accuracy	±2 % of range*, deviations with high viscous media	
Repeatability	±0.5 % or ±1 %, see temperature ranges ambient	
Temperature measuring		
Measuring range	0...90 °C	
Measuring range	32...194 °F	
Accuracy	±1 k	
Response time		
→ t ₅₀	approx. 1 s	
→ t ₉₀	approx. 3 s	
Temperature ranges		
Medium	-20...90 °C	
Medium	-4...194 °F	
Ambient	-20...70 °C	
Ambient	-4...158 °F	
Electrical data		
Electrical connection	5-pin plug connector M12 x 1	
Power supply		
→ Push Pull (optional NPN)	8...30 V DC	
→ NPN	5 V DC (±5 %)	
→ 4...20 mA or 0...10 V	12...24 V DC (±10 %)	
Current consumption	< 15 mA	
Approvals		
		
		
<ul style="list-style-type: none"> • Conforms to ANSI UL Std. 61010-1 • Cert. to CAN/CSA C22.2 No. 61010-1 		

- * Test conditions:
- Test medium water
 - Media temperature 20...30 °C / 68...86 °F
 - Defined inlet and outlet pipes (see operating manual)

Output signals

Three different versions available:

- Frequency output (1)
- Analogue 0.5...3.5 V and frequency output (1 + 2)
- Analogue 0...10 V or 4...20 mA and frequency output (1 + 3)

Frequency output 1	VVX32	VVX40
Output signal flow for power supply → 8...30 V DC → 5 V DC	Frequency signal, square wave, pulse duty ratio 50:50, signal current max. 20 mA Push Pull NPN open collector	
Pulse rate [1/l]	100	50
Pulse rate [pulses/gallon]	400	200
Output signal temperature	Pt1000 2 wire, class B or NTC 10.74k, B 0/100 3450 or none	

Analogue output 2	VVX32	VVX40
Output signal flow	0.5...3.5 V	
Scaling [l/min]	12...250	22...400
Scaling [US gpm]	3.2...66	5.8...106
Voltage rate [V / l/min] → 0.5...3.5 V	0.0126	0.0079
Voltage rate [V / US gpm] → 0.5...3.5 V	0.0478	0.0299
Output signal temperature	Voltage signal 0.5...3.5 V corresponds to 0...90 °C / 32...194 °F or none	

Analogue output 3	VVX32	VVX40
Output signal flow	0...10 V or 4...20 mA	
Scaling [l/min]	0...250	0...400
Scaling [US gpm]	0...66	0...106
Voltage rate [V / l/min] → 0...10 V	0.04000	0.02500
Current rate [mA / l/min] → 4...20 mA	0.06400	0.04000
Voltage rate [V / US gpm] → 0...10 V	0.1515	0.0943
Current rate [mA / US gpm] → 4...20 mA	0.2424	0.1509

Typical pressure drop

Typical pressure drop VVX32

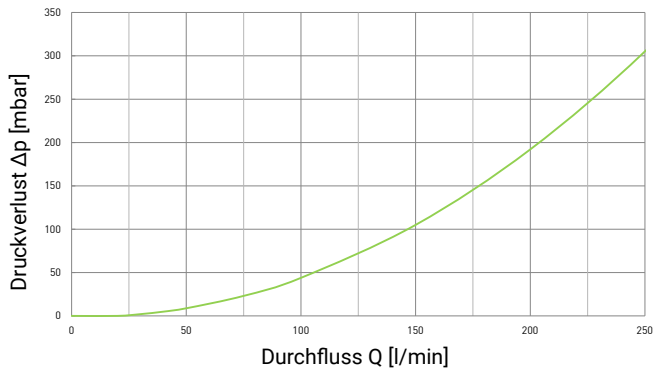

Typical pressure drop VVX32

US version

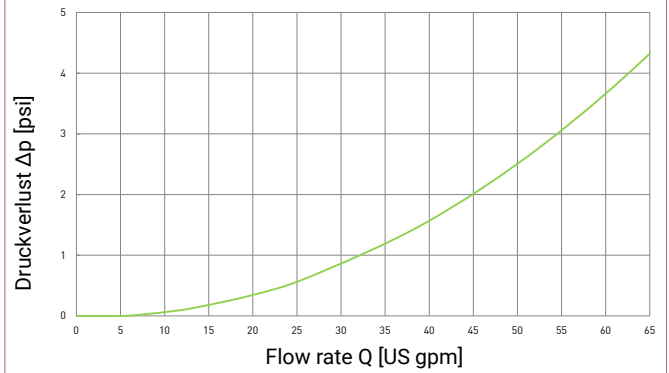

Typical pressure drop VVX40



Typical pressure drop VVX40

US version

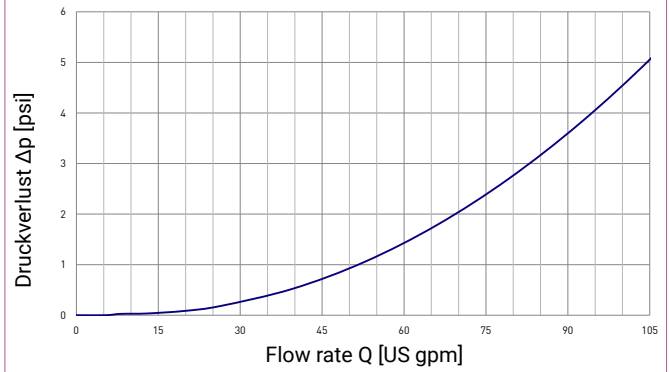

Technical drawing

VVX

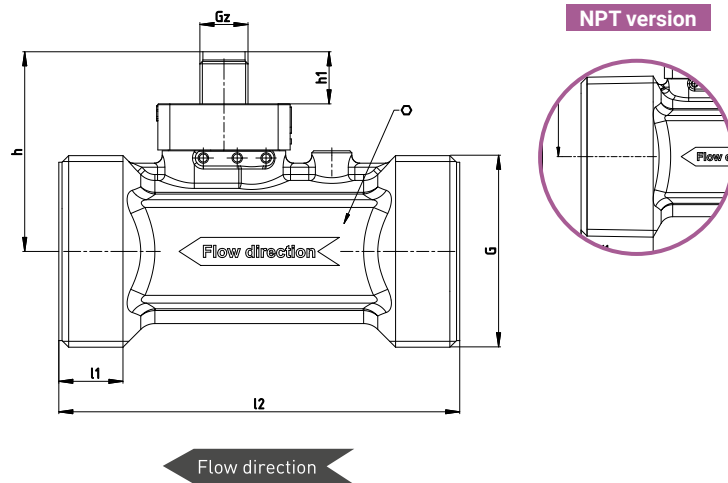

Dimensions

Dimensions [mm]	h	h1	l1	l2	G	Gz	○ Width across flats
VVX32	50	13	16	100	G 1½	M12 x 1	36
VVX40	53.8	13	18	110	G 2	M12 x 1	46
Dimensions [inch]							
VVX32	1.961	0.512	1.024	4.135	1½ - 11.5 NPT	M12 x 1	1.5
VVX40	2.118	0.512	1.063	4.528	2 - 11.5 NPT	M12 x 1	1.875

Materials

Materials in contact with fluid		
VVX32, VVX40	G thread	NPT thread
Body / tube	Brass CW617N-DW or stainless steel 1.4581	Brass CW724R or stainless steel 1.4581
Sensor	ETFE	
O-rings	EPDM	
Immersion sleeve	Brass CW724R or stainless steel 1.4571	
Bluff body	PPS GF40	

Wiring

Pin assignment

The pin assignment depends on the chosen configuration of the device.

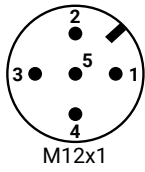

Possible pin assignments:

Pin 1: $+U_B$

Pin 2: $U_{Flow} \cdot R_{Temp}$ • Analog U/I

Pin 3: **GND**

Pin 4: Frequency • Analog U/I • Alarm*¹

Pin 5: $U_{Temp} \cdot R_{Temp}$

*¹ The alarm output is only possible with the corresponding firmware and has been determined during the order.

Wire the connecting cable according to your device version and the pin assignments shown on the type plate.

Supply voltage

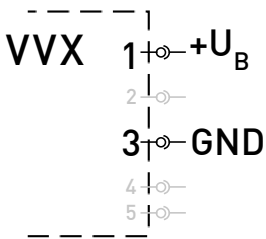

VVX with frequency output

Flow

Push-Pull*¹

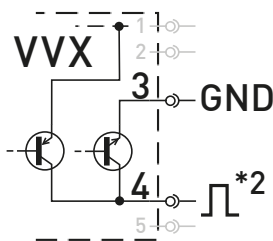

NPN Open Collector

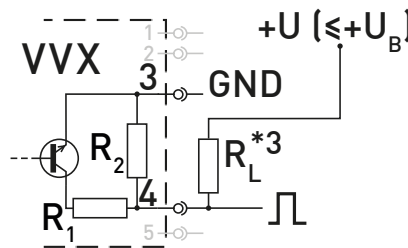

$R_1 \leq 47 \Omega / R_2 \geq 10 \text{ k}\Omega$

PNP Open Collector

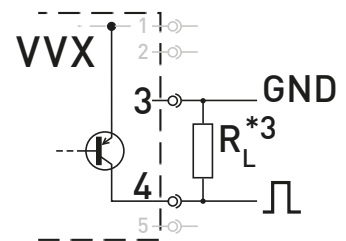

*¹: Not at 5 V.

*²: Do not wire the push-pull switch outputs of multiple VVX devices in parallel.

*³: Recommended pull-up / pull-down resistance $R_L \sim 5 \text{ k}\Omega$.

VVX with temperature (optional)

NTC / Pt 1000

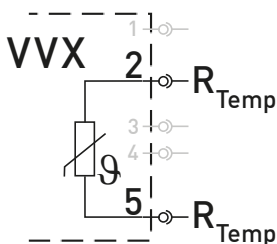

Wiring

VVX with analogue output 0.5...3.5 V (optional)

Flow U_{Flow}

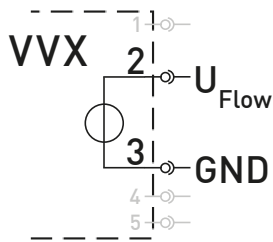

Temperature U_{Temp}

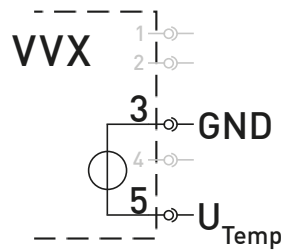

VVX with voltage 0...10 V or current output 4...20 mA (optional)

Flow

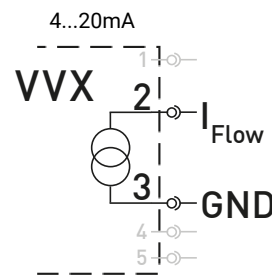
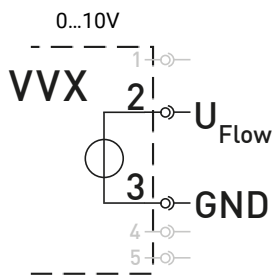

Use of frequency output and optional functions

The frequency output can be wired together with the optional functions. However, not every combination is possible.

In principle, the pins 2, 4 and 5 can only be assigned with one function at a time. A multiple assignment is not possible.

The wiring results from an overlay of the circuit diagrams of the corresponding functions, as shown in the two following examples.

Flow NPN + Analogue 0.5...3.5V

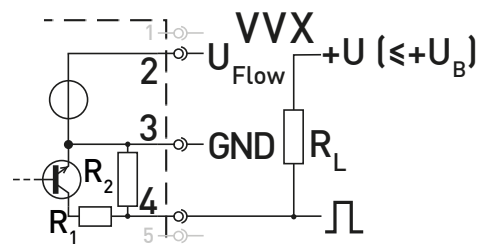

$R1 \leq 47 \Omega$ / $R2 \geq 10 \text{ k}\Omega$

Recommendation for resistance $R_L \sim 5 \text{ k}\Omega$

Flow Push-Pull + current 4...20 mA

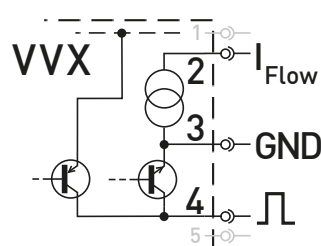

Article numbers

Version frequency output

Order code									
Nominal diameter									
VVX32, DN 32, brass	VVXDD			B					51U
VVX40, DN 40, brass	VVXEE			P					52X
VVX32, DN 32, stainless steel	VVXDD			B					51M
VVX40, DN 40, stainless steel	VVXEE			P					52O
Version									
Standard version		S							
Version with ETL-Approval		E							
Power supply									
8...30 V DC				G				1	
5 V DC				N				2	
Output signal temperature									
Pt1000							RRRP		
NTC 10.74K							RRRN		
None							0000		
Example order number									
	VVXDD	S	G	B	RRRP	1			51U

Order code									
Nominal pipe size									
VVX32, 1 ½" NPT, brass	VVXDF			2					510
VVX40, 2" NPT, brass	VVXEG			T					529
VVX32, 1 ½" NPT, stainless steel	VVXDF			2					51Y
VVX40, 2" NPT, stainless steel	VVXEG			T					52Z
Version									
Standard version		S							
Version with ETL-Approval		E							
Power supply									
8...30 V DC				G				1	
5 V DC				N				2	
Output signal temperature									
Pt1000							RRRP		
NTC 10.74K							RRRN		
None							0000		
Example order number									
	VVXDF	S	G	2	RRRP	1			510

Article numbers

Version analogue output (0.5...3.5 V) and frequency output

Order code									
Nominal diameter									
VVX32, DN 32, brass	VVXDD		NB	UI					51U
VVX40, DN 40, brass	VVXEE		NP	UM					52X
VVX32, DN 32, stainless steel	VVXDD		NB	UI					51M
VVX40, DN 40, stainless steel	VVXEE		NP	UM					52O
Version									
Standard version		S							
Version with ETL-Approval		E							
Output signal temperature									
0.5...3.5 V							U1		
none							00		
Power supply									
8...30 V DC								1	
5 V DC								2	
Example order number	VVXEE	S	NP	UM	U1	1	1	52X	

Order code									
Nominal pipe size									
VVX32, 1 ½" NPT, brass	VVXDF		N2	UO					510
VVX40, 2" NPT, brass	VVXEG		NT	UT					529
VVX32, 1 ½" NPT, stainless steel	VVXDF		N2	UO					51Y
VVX40, 2" NPT, stainless steel	VVXEG		NT	UT					52Z
Version									
Standard version		S							
Version with ETL-Approval		E							
Output signal temperature									
0.5...3.5 V							U1		
none							00		
Power supply									
8...30 V DC								1	
5 V DC								2	
Example order number	VVXDF	S	N2	UO	U1	1	1	510	

Article numbers

Version analogue output (0...10 V or 4...20 mA) and frequency output

Order code				
Nominal diameter				
VVX32, DN 32, brass	VVXDD		GB	X00351U
VVX40, DN 40, brass	VVXEE		GP	Y00352X
VVX32, DN 32, stainless steel	VVXDD		GB	X00351M
VVX40, DN 40, stainless steel	VVXEE		GP	Y00352O
Version				
Standard version		S		
Version with ETL-Approval		E		
Output signal flow				
0...10 V			V	
4...20 mA			A	
Example order number	VVXDD	S	GB	A X00351U

Order code				
Nominal pipe size				
VVX32, 1 1/2" NPT, brass	VVXDF		G2	D003510
VVX40, 2" NPT, brass	VVXEG		GT	Z003529
VVX32, 1 1/2" NPT, stainless steel	VVXDF		G2	D00351Y
VVX40, 2" NPT, stainless steel	VVXEG		GT	Z00352Z
Version				
Standard version		S		
Version with ETL-Approval		E		
Output signal flow				
0...10 V			V	
4...20 mA			A	
Example order number	VVXDF	S	G2	V D003510

Order code	
Service	Order number
Works calibration certificate for sample devices	VVXWPS01

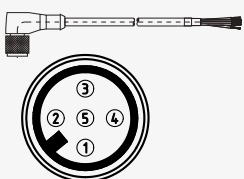
Order code				
Type	Accessories	Length [m]	Length [ft]	Order number
VVX32 VVX40		1		XVVX040
		2		XVVX051
		3		XVVX039
			10	XVVX017
			16	XVVX018
	33	XVVX019		

* Connection cables with UL approval on request